

C. Flush tank detail

VARIABLE DIMENSIONS

Gutter width, feet	4	5	6
Tank width, inches	41	53	65
Back splash width, inches	47	59	71
Flush volume, gallons	180	230	280
Counterbalance, pounds	95	119	144

D. Splash surface

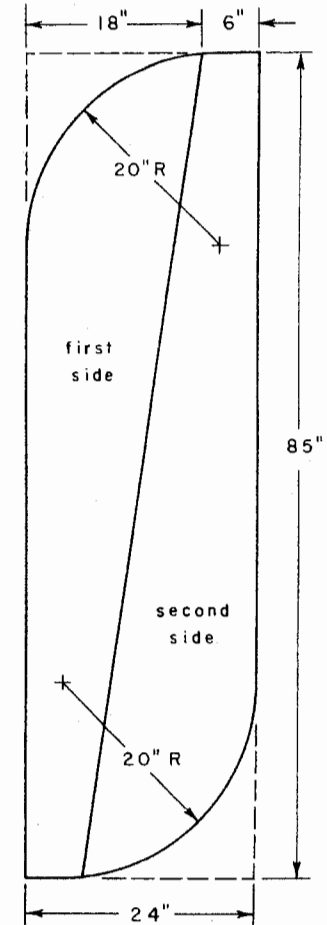
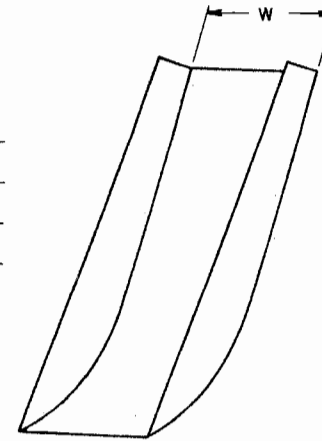

E. Cut out pattern for splash surface

F. Detail shock absorber mount - two required.

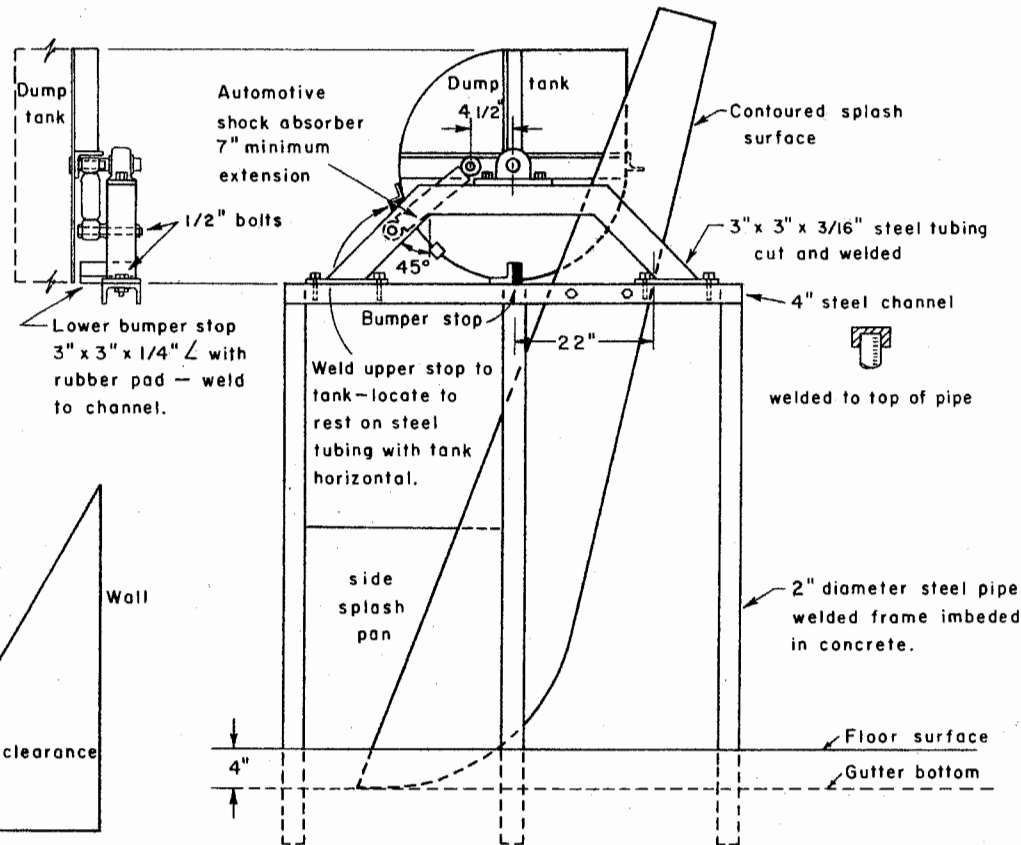

A. Assembly

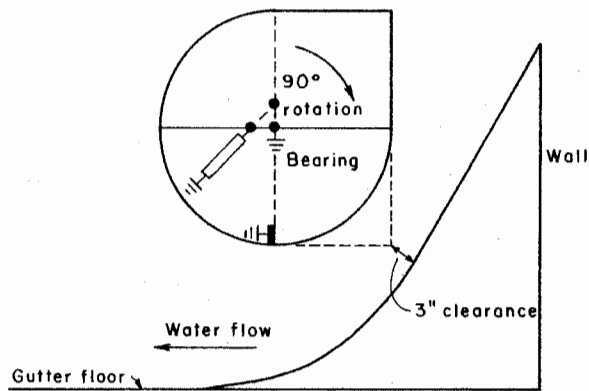

B. Dumping mode



SCALE: 0.1" = 1.0" except where otherwise noted

BASED ON UNIV. OF MD. PLAN 75-1-4



CIRCULAR FLUSH TANK SELF-DUMPING

MD. '76 6 2 3 8 SHEET 1 OF 1

## Disclaimer

This site makes available conceptual plans that can be helpful in developing building layouts and selecting equipment for various agricultural applications. These plans do not necessarily represent the most current technology or construction codes. They are not construction plans and do not replace the need for competent design assistance in developing safe, legal and well-functioning agricultural building system. The LSU Agriculture Center, the Mid-West Plan Service, the United States Department of Agriculture and none of the cooperating land-grant universities warranty these plans.